



Five Pin Soil Sensor
Product Manual



1 overview

The five-pin soil sensor has stable performance, high sensitivity, fast response, and stable output, and is suitable for various soil qualities . It is an important tool for observing and studying the occurrence, evolution, improvement and water-salt dynamics of saline soil. By measuring the dielectric constant of soil, it can directly and stably reflect the real moisture content of various soils. It can measure the volume percentage of soil moisture, which is a soil moisture measurement method in line with current international standards. Can be buried in the soil for a long time, resistant to long-term electrolysis, corrosion resistance, vacuum potting, completely waterproof .

2 features

- (1) The sensor is compact in size .
- (2) High measurement accuracy, fast response and good interchangeability .
- (3) It has good sealing performance and can be directly buried in the soil for use without corrosion .
- (4) The influence of soil quality is small, and the application area is wide .
- (5) Accurate measurement, reliable performance, ensuring normal operation , and high data transmission efficiency .

3 scope of application

It is suitable for temperature and humidity, electrical conductivity, and PH value testing in soil moisture monitoring, scientific experiments, water-saving irrigation, greenhouses, flowers and vegetables, grassland pastures, soil rapid testing, plant cultivation, sewage treatment, precision agriculture, etc.

4 Product information

4.1 Technical parameters

Measurement parameters: soil electrical conductivity (EC value), temperature, moisture, PH value, nitrogen, phosphorus and potassium

Measuring range: 0~20000 μ S/cm, -40~80 $^{\circ}$ C, 0-100%, 3~9PH, 1-1999 mg/kg(mg/L)

Measurement accuracy : $\pm 2\%$, $\pm 0.5^{\circ}$ C, $\pm 2\%$ within 0-50%, $\pm 3\%$ within 50-100%, ± 0.3 PH, $\pm 2\%$ FS

point identify Rate: 1 μ S/cm, 0.1 $^{\circ}$ C, 0.1%, 0.1, 1 mg/kg(mg/L)

Output signal: RS485 (ModBus-RTU protocol)

Power supply voltage: 4.5 ~ 30V DC

Working range: - 30 $^{\circ}$ C ~ 70 $^{\circ}$ C

Stabilization time: 1 second after power on

Response time: < 1 second

4.2 Physical parameters

Probe length: 55mm , ϕ 3mm

Probe material: 316L stainless steel

Sealing material: ABS engineering plastics , epoxy resin, waterproof grade IP68

Cable specification: standard 2 meters (other cable lengths can be customized, up to 1200 meters)

Load capacity: voltage output: output resistance \leq 250 Ω ; current output: \leq 600 Ω

4.3 Product selection

ZTS-				company code
	3001-			
		TR-		Soil Testing Housing
			TH NPK PH -	Temperature Moisture Nitrogen Phosphorus Potassium PH Transmitter
			ECTHNPCKPH-	Conductivity Temperature Moisture Nitrogen Phosphorus Potassium PH Transmitter
			THPH-	Temperature Moisture pH Transmitter
			ECTHPH-	Conductivity Temperature Moisture PH Value Transmitter
				N01 RS485 (Modbus-RTU protocol)

5 form factor

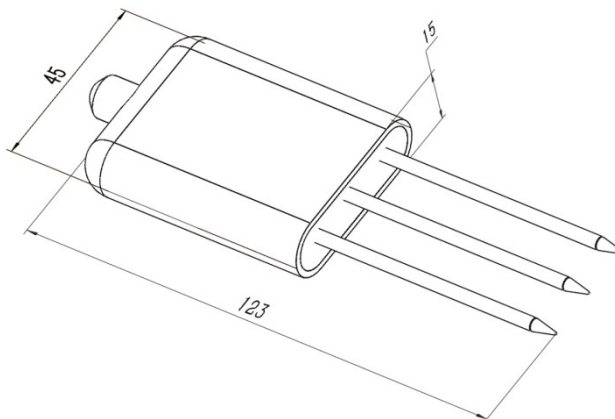

6 Instructions

The soil conductivity sensor can be connected to various data collectors with differential inputs, data acquisition cards, remote data acquisition modules and other equipment. The wiring instructions are as follows:

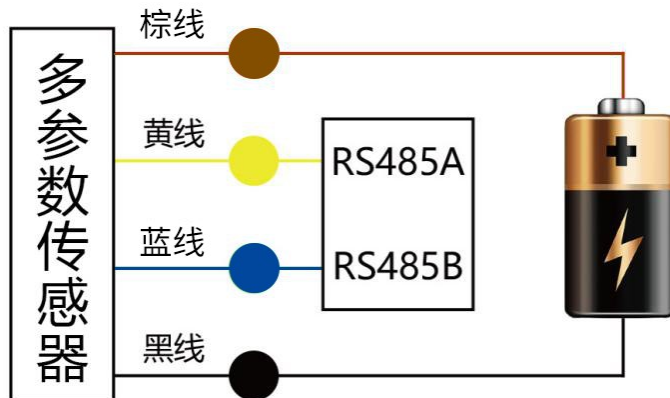

7 data conversion method

RS485 signal (default address 01):

Standard Modbus-RTU protocol, baud rate: 48 00; parity bit: none; data bit: 8 ; stop bit: 1

7.1 Modify address

For example: Change the address of the sensor with address 1 to 2,
master → slave

original address	function code	start register high	start register low	start address high	low starting address	CRC16 low	CRC16 high
0 X 01	0 X 06	0X0 7	0X D 0	0X00	0X02	0 X08	0 X86

If the sensor is received correctly, the data will be returned in the same way .

Remarks: If you forget the original address of the sensor, you can use the broadcast address 0 XFF instead . When using 0 XFF , the master can only connect to one slave , and the return address is still the original address, which can be used as an address query method.

7.2 Query data

register address

register address	PLC or configuration address	content	operate	Definition
0000H	40001 (decimal)	moisture content	read only	Real-time value of moisture content

				(enlarged by 10 times)
0001H	40002 (decimal)	temperature value	read only	Temperature real- time value (enlarged by 10 times)
0002H	40003 (decimal)	Conductivit y	read only	Conductivity real- time value
0003H	40004 (decimal)	PH value	read only	PH real-time value (enlarged ten times)
0004H	40005 (decimal)	nitrogen content	read only	Nitrogen content actual value
0005H	40006 (decimal)	Phosphorus content	read only	Phosphorus content actual value
0006H	40007(decima l)	potassium content	read only	Potassium content actual value
07D0H	42001 (decimal)	device address	read and write	1~254 (factory default 1)
07D1H	42002	Device baud	read	0 means 2400

	(decimal)	rate	and write	1 for 4800 2 stands for 9600
--	-----------	------	--------------	---------------------------------

Query the data of the conductivity temperature moisture PH value sensor (address 1), host → slave

address	function code	Start register address high	Start Register Address Low	high register length	low register length	CRC1 6 low	CRC1 6 high
0X01	0X03	0X00	0X00	0X00	0X04	0X44	0X09

If the sensor is received correctly, return the following data, slave → host

address code	function code	return valid Bytes	Moisture value	temperature value	Conductivity value	PH value	check code low byte	check code

								high byte
0x01	0x03	0x08	0x02 0x92	0xFF 0x9B	0x03 0xE8	0x00 0x38	0x57	0xB6

Temperature calculation:

When the temperature is lower than 0 °C, the temperature data is uploaded in the form of complementary code.

Temperature: FF9B H(Hex)= -101 => Temperature= -10.1°C

Moisture calculation:

Moisture: 292 H (hexadecimal) = 658 => humidity = 65.8%, that is, the soil volume moisture content is 65.8%.

Conductivity calculation:

Conductivity : 3E8 H (hexadecimal) = 1000 Conductivity = 1000 us/cm

PH value calculation:

PH value: 38H (hexadecimal) = 56 => PH value = 5.6

8 Precautions for use

police tell

- ⊗ Failure to follow the wiring sequence may cause damage to the device and the instrument connected to the device .
- ⊗ When the input power exceeds the maximum input power of the device, it will cause damage to the device .

Note meaning

- △ Please read this manual completely before use .
- △ Do not attempt to insert the probe into stones or hard clods as this may damage the probe .
- △ Do not pull directly on the cable when moving the sensor out of the soil .
- △ The sensor probe should be fully inserted into the soil / substrate to reduce operational errors and improve measurement accuracy .

9 product warranty

The warranty period of this product is one year. Counting from the date of delivery, within 12 months, the company is responsible for free repair or replacement of faults caused by sensor quality problems (non-human damage), and only the cost will be charged after the warranty period .